



**EASY
HANDLING**

**NPPL12WPTP
NPPL12IPTP
NPPL12MPTP
NPPL12HPTP
NPPL12KPTP
NPPL12JPTP
NPPL12MPSP**

**NPPL15WPTP
NPPL15IPTP
NPPL15MPTP
NPPL15HPTP
NPPL15KPTP
NPPL15JPTP
NPPL15MPSP**

SPECIFICATIONS

ELECTRIC HAND PALLET TRUCK 48V, 1.2 - 1.5 TONNES



ENGINEERED FOR MAXIMUM PRODUCTIVITY WITH MINIMUM TOTAL COST OF OWNERSHIP

AN IDEAL SOLUTION FOR TRANSPORTING LOADS UP TO 1.5 TONNES. IT EXCELS IN LIGHT TO MEDIUM-DUTY INDOOR APPLICATIONS SUCH AS: WORKSHOP, RETAIL, SMALL SUPER MARKET, CARGO CONTAINERS AND GENERAL WAREHOUSING.

Multi functional ergonomic control handle with stepless speed control.

High capacity Li-ion battery 48V/20Ah provides maintenance-free operation with 6 hrs working time and only 3.5 hours charging time.

Taper Fork Tip and Tandem PU Rollers with Fork tip rollers for easy pallet entry and exit.

Supplied with included external charger.

Ergonomic Spring loaded Steering Handle with comfort grip for reduced operator fatigue.

Hub Motor with patented design with no gears and no brushes. The motor is practically noiseless and maintenance free.

Regenerative Brake System with electromagnetic disk brake improves the braking performance and working life of it. The kinetic energy also charges the battery.

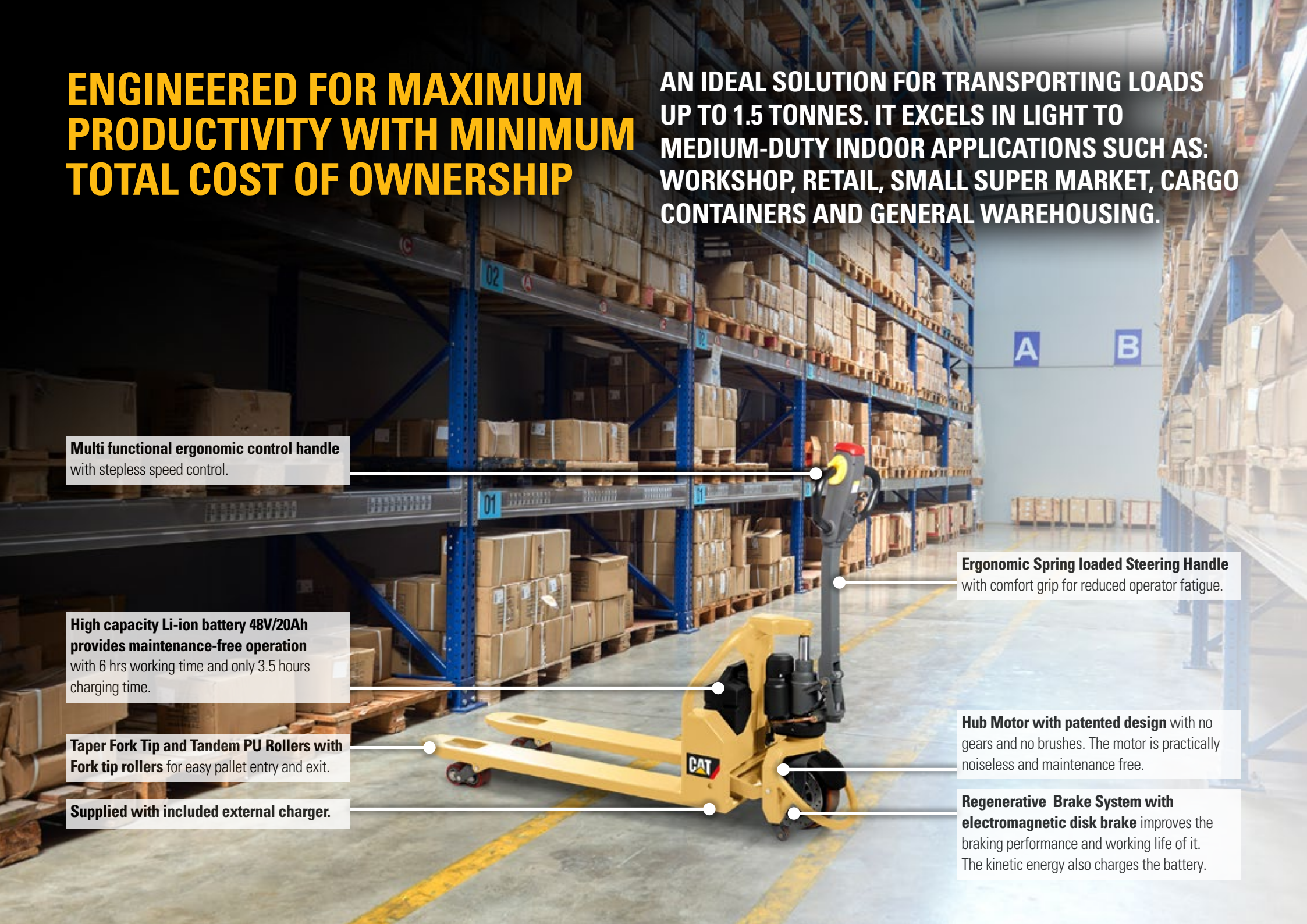

LOWER COST OF OWNERSHIP

- Removable easy exchangeable maintenance-free high capacity 48V Lithium-Ion battery provides 6 hours effective use and is interchangeable between 1.2 and 1.5 tonne models.
- External charger, possible to charge the battery onboard with only 3.5 hours charging time.
- Maintenance free brushless (AC) and gearless wheel hub motor with no wearable components, like carbon brushes or contactors, to replace over time.
- Easy maintenance with no expensive handheld required, only a laptop, software, and cable. Unscrew the cover and connect the cable to your device.
- Convenient to replace the steering wheel.
- 1.5 tonne model features additional reinforcement to the chassis and tapered fork tips for easy pallet entry.
- Integrated rocker arm constructed from a single-piece casting of solid steel for high strength and durability (1.5 tonne model).

UNMATCHED PRODUCTIVITY

- High quality stable construction gives a stable and durable platform.
- Suitability for short and mid-distance runs makes the truck highly flexible and further enhances productivity.
- Compact design, low service weight and small turning radius allows it to be used in confined spaces such as: retail, trailers, containers, and small warehouses.
- 1.5 tonne model features double brake discs for optimal braking performance.

SAFETY AND ERGONOMICS

- Multi-function control handle incorporates: butterfly-style thumb controls, emergency reverse button, horn button, and key switch.
- Ergonomic spring-loaded steering handle with comfort grip for reduced operator fatigue.
- Integrated battery status indicator.
- Fork tip rollers for easy pallet entry and exit.
- A single piece casted rocker arm for strength and stability.
- No leaking hazardous battery gases and acids while charging does not require watering, Lithium-ion technology makes interim charges possible.



**THE AGILE, EFFORTLESS AND COST-EFFECTIVE
HAND PALLET TRUCK ALTERNATIVE.**

IDEAL IN MANY APPLICATIONS.

Characteristics		
1.1	Manufacturer	
1.2	Manufacturer's model designation	
1.3	Power source	
1.4	Operator type	
1.5	Load capacity	Q (kg)
1.6	Load center distance	c (mm)
1.8	Load wheel axle to fork face (forks lowered)	x (mm)
1.9	Wheelbase	y (mm)
Weight		
2.1	Truck weight with load, with maximum battery weight	kg
2.2	Axle loadings with nominal load & maximum battery weight, drive/load side	kg
2.3	Axle loadings without load & with maximum battery weight, drive/load side	kg
Wheels, Drive Train		
3.1	Tyres: PT=Power Thane, Vul=Vulkollan, P=Polyurethane, N=Nylon, R=Rubber drive/load side	
3.2	Tyre dimensions, drive side	ø (mm)
3.3	Tyre dimensions, load side	ø (mm)
3.5	Number of wheels, load/drive side (x=driven)	
Dimensions		
4.4	Lift height	h3 (mm)
4.9	Height of tiller arm / steering console (min./max.)	h14 (mm)
4.15	Fork height, fully lowered	h13 (mm)
4.19	Overall length	l1 (mm)
4.20	Length to fork face	l2 (mm)
4.21	Overall width	b1/b2 (mm)
4.22	Fork dimensions (thickness, width, length)	s,e,l (mm)
4.25	Outside width over forks (minimum/maximum)	b5 (mm)
4.32	Ground clearance at center of wheelbase, (forks lowered)	m2 (mm)
4.33b	Working aisle width (Ast3) with 1000 x 1200 mm pallets, load crosswise	Ast3 (mm)
4.34b	Working aisle width (Ast3) with 800 x 1200 mm pallets, load lengthwise	Ast3 (mm)
4.35	Turning radius	Wa (mm)
Performance		
5.1	Travel speed, with/without load	km/h
5.2	Lifting speed, with/without load	m/s
5.3	Lowering speed, with/without load	m/s
5.8	Maximum gradeability, with/without load	%
Electric motors		
6.1	Drive motor capacity (60 min. short duty)	kW
6.2	Lift motor output at 15% duty factor	kW
6.4	Battery voltage/capacity at 5-hour discharge	V/Ah
6.5	Battery weight	kg
6.6a	Energy consumption according to VDI 60 cycle	kWh/h
Miscellaneous		
10.7	Level of noise at the ear level of the driver according to EN 12 053:2001 and EN ISO 4871 in work LpAZ	dB(A)

Cat Lift Trucks	Cat Lift Trucks
NPPL12WPTP 550 X 1000	NPPL12IPTP 680 X 1000
Battery	Battery
Pedestrian	Pedestrian
1200	1200
600	600
802	802
1119	1119
135	140
450/885	450/890
110/25	115/25
P	P
250	250
80	80
1x/4	1x/4
110	110
635/1200	635/1200
80	80
1501	1501
501	501
550	680
45/160/1000	45/160/1000
550	680
35	35
1700	1700
1900	1900
1302	1302
4/4.5	4/4.5
0.02/0.025	0.02/0.025
Manual control	Manual control
5/20	5/20
0.8	0.8
0.6	0.6
48/20	48/20
8	8
0.15	0.15
70	70

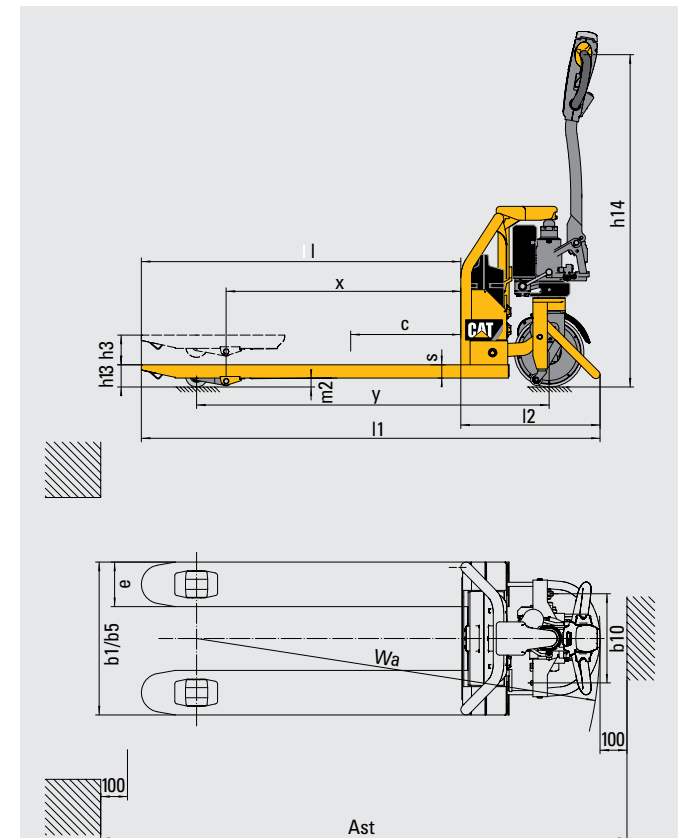

Ast3 = Wa + length of pallet - x + 2*100



Characteristics		
1.1	Manufacturer	
1.2	Manufacturer's model designation	
1.3	Power source	
1.4	Operator type	
1.5	Load capacity	Q (kg)
1.6	Load center distance	c (mm)
1.8	Load wheel axle to fork face (forks lowered)	x (mm)
1.9	Wheelbase	y (mm)
Weight		
2.1	Truck weight with load, with maximum battery weight	kg
2.2	Axle loadings with nominal load & maximum battery weight, drive/load side	kg
2.3	Axle loadings without load & with maximum battery weight, drive/load side	kg
Wheels, Drive Train		
3.1	Tyres: PT=Power Thane, Vul=Vulkollan, P=Polyurethane, N=Nylon, R=Rubber drive/load side	
3.2	Tyre dimensions, drive side	ø (mm)
3.3	Tyre dimensions, load side	ø (mm)
3.5	Number of wheels, load/drive side (x=driven)	
Dimensions		
4.4	Lift height	h3 (mm)
4.9	Height of tiller arm / steering console (min./max.)	h14 (mm)
4.15	Fork height, fully lowered	h13 (mm)
4.19	Overall length	l1 (mm)
4.20	Length to fork face	l2 (mm)
4.21	Overall width	b1/b2 (mm)
4.22	Fork dimensions (thickness, width, length)	s,e,l (mm)
4.25	Outside width over forks (minimum/maximum)	b5 (mm)
4.32	Ground clearance at center of wheelbase, (forks lowered)	m2 (mm)
4.33b	Working aisle width (Ast3) with 1000 x 1200 mm pallets, load crosswise	Ast3 (mm)
4.34b	Working aisle width (Ast3) with 800 x 1200 mm pallets, load lengthwise	Ast3 (mm)
4.35	Turning radius	Wa (mm)
Performance		
5.1	Travel speed, with/without load	km/h
5.2	Lifting speed, with/without load	m/s
5.3	Lowering speed, with/without load	m/s
5.8	Maximum gradeability, with/without load	%
Electric motors		
6.1	Drive motor capacity (60 min. short duty)	kW
6.2	Lift motor output at 15% duty factor	kW
6.4	Battery voltage/capacity at 5-hour discharge	V/Ah
6.5	Battery weight	kg
6.6	Energy consumption according to VDI 60 cycle	kWh/h
Miscellaneous		
10.7	Level of noise at the ear level of the driver according to EN 12 053:2001 and EN ISO 4871 in work LpAZ	dB(A)

Cat Lift Trucks	Cat Lift Trucks	Cat Lift Trucks
NPPL12MPTP 550 X 1150	NPPL12MPSP 550 X 1150	NPPL12HPTP 680 X 1150
Battery	Battery	Battery
Pedestrian	Pedestrian	Pedestrian
1200	1200	1200
600	600	600
952	952	952
1269	1269	1269
140	137.5	150
450/890	450/887.5	460/890
110/30	110/27.5	120/30
P	P	P
250	250	250
80	80	80
1x/4	1x/2	1x/4
110	110	110
635/1200	635/1200	635/1200
80	80	80
1651	1651	1651
501	501	501
550	550	680
45/160/1150	45/160/1150	45/160/1150
550	550	680
35	35	35
1850	1850	1850
1900	1900	1900
1452	1452	1452
4/4.5	4/4.5	4/4.5
0.02/0.025	0.02/0.025	0.02/0.025
Manual control	Manual control	Manual control
5/20	5/20	5/20
0.8	0.8	0.8
0.6	0.6	0.6
48/20	48/20	48/20
8	8	8
0.15	0.15	0.15
70	70	70

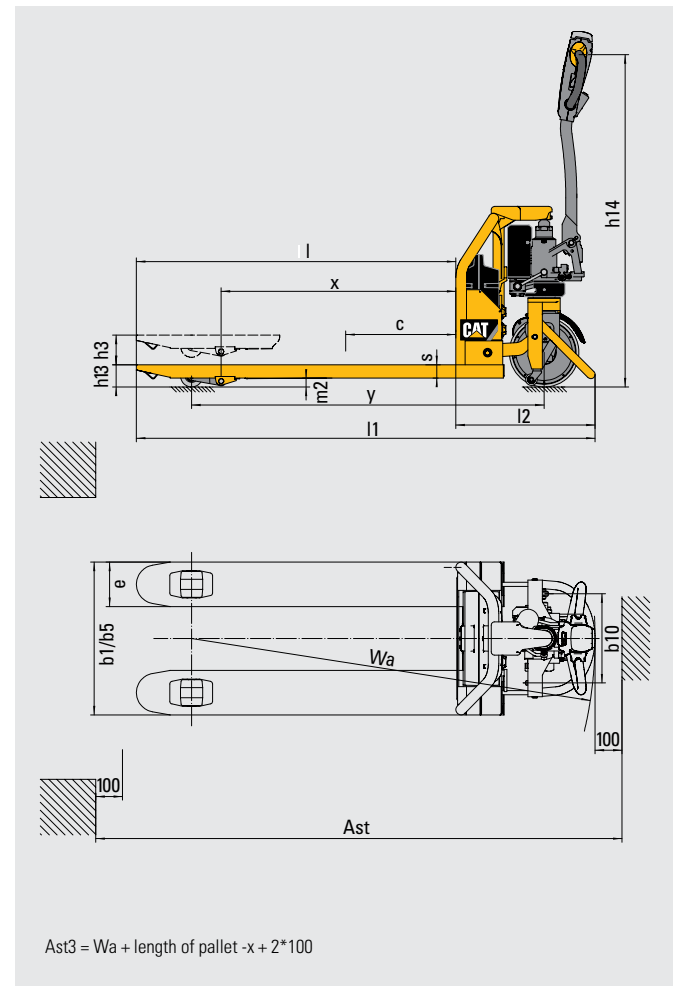

Characteristics		
1.1	Manufacturer	
1.2	Manufacturer's model designation	
1.3	Power source	
1.4	Operator type	
1.5	Load capacity	Q (kg)
1.6	Load center distance	c (mm)
1.8	Load wheel axle to fork face (forks lowered)	x (mm)
1.9	Wheelbase	y (mm)
Weight		
2.1	Truck weight with load, with maximum battery weight	kg
2.2	Axle loadings with nominal load & maximum battery weight, drive/load side	kg
2.3	Axle loadings without load & with maximum battery weight, drive/load side	kg
Wheels, Drive Train		
3.1	Tyres: PT=Power Thane, Vul=Vulkollan, P=Polyurethane, N=Nylon, R=Rubber drive/load side	
3.2	Tyre dimensions, drive side	ø (mm)
3.3	Tyre dimensions, load side	ø (mm)
3.5	Number of wheels, load/drive side (x=driven)	
Dimensions		
4.4	Lift height	h3 (mm)
4.9	Height of tiller arm / steering console (min./max.)	h14 (mm)
4.15	Fork height, fully lowered	h13 (mm)
4.19	Overall length	l1 (mm)
4.20	Length to fork face	l2 (mm)
4.21	Overall width	b1/b2 (mm)
4.22	Fork dimensions (thickness, width, length)	s,e,l (mm)
4.25	Outside width over forks (minimum/maximum)	b5 (mm)
4.32	Ground clearance at center of wheelbase, (forks lowered)	m2 (mm)
4.33b	Working aisle width (Ast3) with 1000 x 1200 mm pallets, load crosswise	Ast3 (mm)
4.34b	Working aisle width (Ast3) with 800 x 1200 mm pallets, load lengthwise	Ast3 (mm)
4.35	Turning radius	Wa (mm)
Performance		
5.1	Travel speed, with/without load	km/h
5.2	Lifting speed, with/without load	m/s
5.3	Lowering speed, with/without load	m/s
5.8	Maximum gradeability, with/without load	%
Electric motors		
6.1	Drive motor capacity (60 min. short duty)	kW
6.2	Lift motor output at 15% duty factor	kW
6.4	Battery voltage/capacity at 5-hour discharge	V/Ah
6.5	Battery weight	kg
6.6	Energy consumption according to VDI 60 cycle	kWh/h
Miscellaneous		
10.7	Level of noise at the ear level of the driver according to EN 12 053:2001 and EN ISO 4871 in work LpAZ	dB(A)

Cat Lift Trucks	Cat Lift Trucks
NPPL12KPTP 550 X 1220	NPPL12JPTP 680 X 1220
Battery	Battery
Pedestrian	Pedestrian
1200	1200
600	600
1022	1022
1339	1339
144	154
454/890	464/890
110/34	120/34
P	P
250	250
80	80
1x/4	1x/4
110	110
635/1200	635/1200
80	80
1721	1721
501	501
550	680
45/160/1220	45/160/1220
550	680
35	35
1920	1920
1920	1920
1522	1522
4/4.5	4/4.5
0.02/0.025	0.02/0.025
Manual control	Manual control
5/20	5/20
0.8	0.8
0.6	0.6
48/20	48/20
8	8
0.15	0.15
70	70

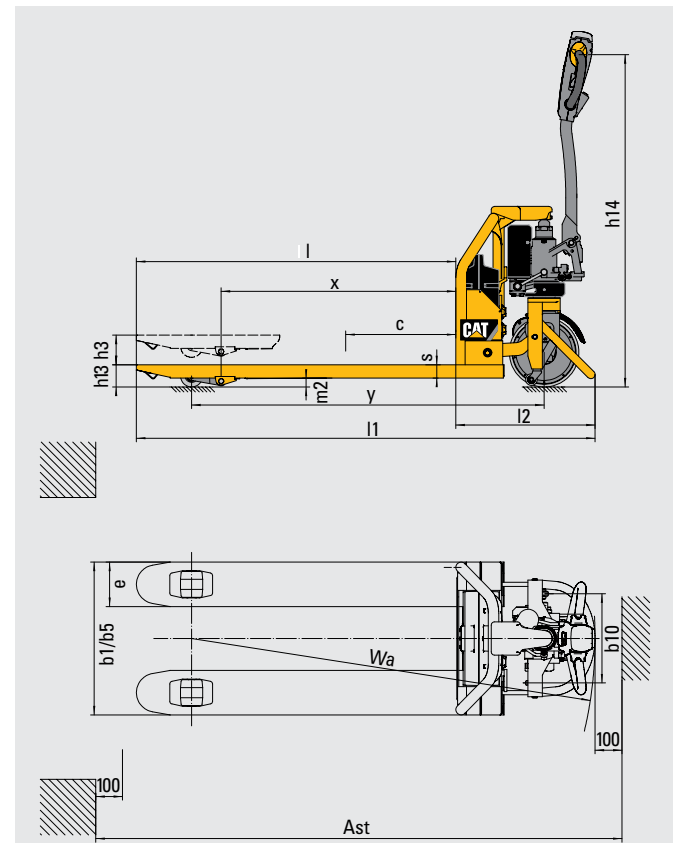

Ast3 = Wa + length of pallet - x + 2*100



Characteristics		
1.1	Manufacturer	
1.2	Manufacturer's model designation	
1.3	Power source	
1.4	Operator type	
1.5	Load capacity	Q (kg)
1.6	Load center distance	c (mm)
1.8	Load wheel axle to fork face (forks lowered)	x (mm)
1.9	Wheelbase	y (mm)
Weight		
2.1	Truck weight with load, with maximum battery weight	kg
2.2	Axle loadings with nominal load & maximum battery weight, drive/load side	kg
2.3	Axle loadings without load & with maximum battery weight, drive/load side	kg
Wheels, Drive Train		
3.1	Tyres: PT=Power Thane, Vul=Vulkollan, P=Polyurethane, N=Nylon, R=Rubber drive/load side	
3.2	Tyre dimensions, drive side	ø (mm)
3.3	Tyre dimensions, load side	ø (mm)
3.5	Number of wheels, load/drive side (x=driven)	
Dimensions		
4.4	Lift height	h3 (mm)
4.9	Height of tiller arm / steering console (min./max.)	h14 (mm)
4.15	Fork height, fully lowered	h13 (mm)
4.19	Overall length	l1 (mm)
4.20	Length to fork face	l2 (mm)
4.21	Overall width	b1/b2 (mm)
4.22	Fork dimensions (thickness, width, length)	s,e,l (mm)
4.25	Outside width over forks (minimum/maximum)	b5 (mm)
4.32	Ground clearance at center of wheelbase, (forks lowered)	m2 (mm)
4.33b	Working aisle width (Ast3) with 1000 x 1200 mm pallets, load crosswise	Ast3 (mm)
4.34b	Working aisle width (Ast3) with 800 x 1200 mm pallets, load lengthwise	Ast3 (mm)
4.35	Turning radius	Wa (mm)
Performance		
5.1	Travel speed, with/without load	km/h
5.2	Lifting speed, with/without load	m/s
5.3	Lowering speed, with/without load	m/s
5.8	Maximum gradeability, with/without load	%
Electric motors		
6.1	Drive motor capacity (60 min. short duty)	kW
6.2	Lift motor output at 15% duty factor	kW
6.4	Battery voltage/capacity at 5-hour discharge	V/Ah
6.5	Battery weight	kg
6.6	Energy consumption according to VDI 60 cycle	kWh/h
Miscellaneous		
10.7	Level of noise at the ear level of the driver according to EN 12 053:2001 and EN ISO 4871 in work LpAZ	dB(A)

Cat Lift Trucks	Cat Lift Trucks	Cat Lift Trucks	Cat Lift Trucks
NPPL15WPTP 550X1000	NPPL15IPTP 680X1000	NPPL15MPTP 550X1150	NPPL15HPTP 685X1150
Battery	Battery	Battery	Battery
Pedestrian	Pedestrian	Pedestrian	Pedestrian
1500	1500	1500	1500
600	600	600	600
802	802	952	952
1119	1119	1269	1269
140	145	145	155
450/885	450/890	450/890	460/890
110/25	115/25	110/30	120/30
P	P	P	P
250	250	250	250
80	80	80	80
1x/4	1x/4	1x/4	1x/4
110	110	110	110
635/1200	635/1200	635/1200	635/1200
80	80	80	80
1501	1501	1651	1651
501	501	501	501
550	680	550	680
45/160/1000	45/160/1000	45/160/1150	45/160/1150
550	680	550	680
35	35	35	35
1700	1700	1850	1850
1900	1900	1900	1900
1302	1302	1452	1452
4/4.5	4/4.5	4/4.5	4/4.5
0.02/0.025	0.02/0.025	0.02/0.025	0.02/0.025
Manual control	Manual control	Manual control	Manual control
4/20	4/20	4/20	4/20
0.8	0.8	0.8	0.8
0.7	0.7	0.7	0.7
48/20	48/20	48/20	48/20
8	8	8	8
0.15	0.15	0.15	0.15
70	70	70	70

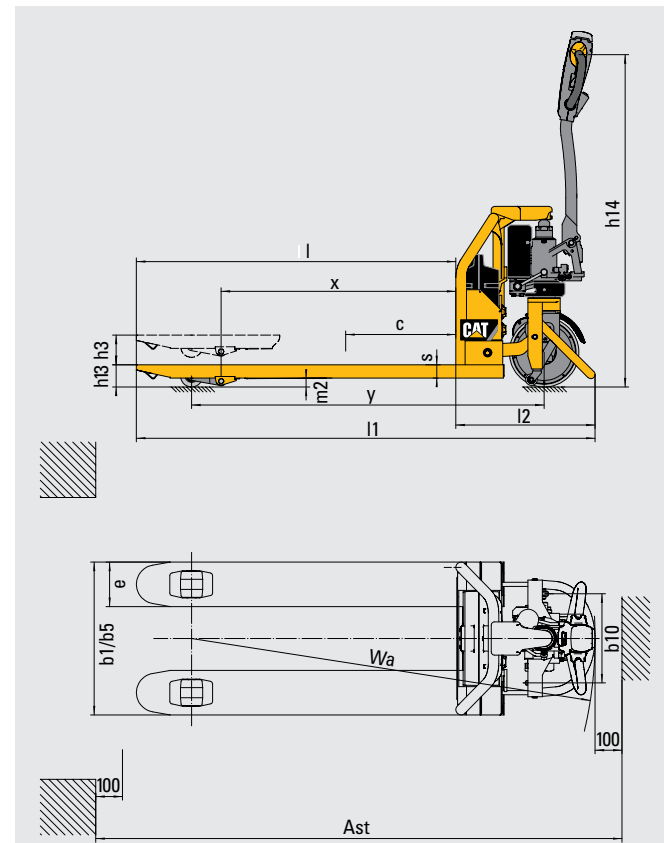

Ast3 = Wa + length of pallet - x + 2*100



Characteristics		
1.1	Manufacturer	
1.2	Manufacturer's model designation	
1.3	Power source	
1.4	Operator type	
1.5	Load capacity	Q (kg)
1.6	Load center distance	c (mm)
1.8	Load wheel axle to fork face (forks lowered)	x (mm)
1.9	Wheelbase	y (mm)
Weight		
2.1	Truck weight with load, with maximum battery weight	kg
2.2	Axle loadings with nominal load & maximum battery weight, drive/load side	kg
2.3	Axle loadings without load & with maximum battery weight, drive/load side	kg
Wheels, Drive Train		
3.1	Tyres: PT=Power Thane, Vul=Vulkollan, P=Polyurethane, N=Nylon, R=Rubber drive/load side	
3.2	Tyre dimensions, drive side	ø (mm)
3.3	Tyre dimensions, load side	ø (mm)
3.5	Number of wheels, load/drive side (x=driven)	
Dimensions		
4.4	Lift height	h3 (mm)
4.9	Height of tiller arm / steering console (min./max.)	h14 (mm)
4.15	Fork height, fully lowered	h13 (mm)
4.19	Overall length	l1 (mm)
4.20	Length to fork face	l2 (mm)
4.21	Overall width	b1/b2 (mm)
4.22	Fork dimensions (thickness, width, length)	s,e,l (mm)
4.25	Outside width over forks (minimum/maximum)	b5 (mm)
4.32	Ground clearance at center of wheelbase, (forks lowered)	m2 (mm)
4.33b	Working aisle width (Ast3) with 1000 x 1200 mm pallets, load crosswise	Ast3 (mm)
4.34b	Working aisle width (Ast3) with 800 x 1200 mm pallets, load lengthwise	Ast3 (mm)
4.35	Turning radius	Wa (mm)
Performance		
5.1	Travel speed, with/without load	km/h
5.2	Lifting speed, with/without load	m/s
5.3	Lowering speed, with/without load	m/s
5.8	Maximum gradeability, with/without load	%
Electric motors		
6.1	Drive motor capacity (60 min. short duty)	kW
6.2	Lift motor output at 15% duty factor	kW
6.4	Battery voltage/capacity at 5-hour discharge	V/Ah
6.5	Battery weight	kg
6.6	Energy consumption according to VDI 60 cycle	kWh/h
Miscellaneous		
10.7	Level of noise at the ear level of the driver according to EN 12 053:2001 and EN ISO 4871 in work LpAZ	dB(A)

Cat Lift Trucks	Cat Lift Trucks	Cat Lift Trucks
NPPL15KPTP 550X1220	NPPL15JPTP 680X1220	NPPL15MPSP 550X1150
Battery	Battery	Battery
Pedestrian	Pedestrian	Pedestrian
1500	1500	1500
600	600	600
1022	1022	952
1339	1339	1269
149	159	142.5
454/890	464/890	450/887.5
110/34	120/34	110/27.5
P	P	P
250	250	250
80	80	80
1x/4	1x/4	1x/2
110	110	110
635/1200	635/1200	635/1200
80	80	80
1721	1721	1651
501	501	501
550	680	550
45/160/1220	45/160/1220	45/160/1150
550	680	550
35	35	35
1920	1920	1850
1920	1920	1900
1522	1522	1452
4/4.5	4/4.5	4/4.5
0.02/0.025	0.02/0.025	0.02/0.025
Manual control	Manual control	Manual control
4/20	4/20	4/20
0.8	0.8	0.8
0.7	0.7	0.7
48/20	48/20	48/20
8	8	8
0.15	0.15	0.15
70	70	70

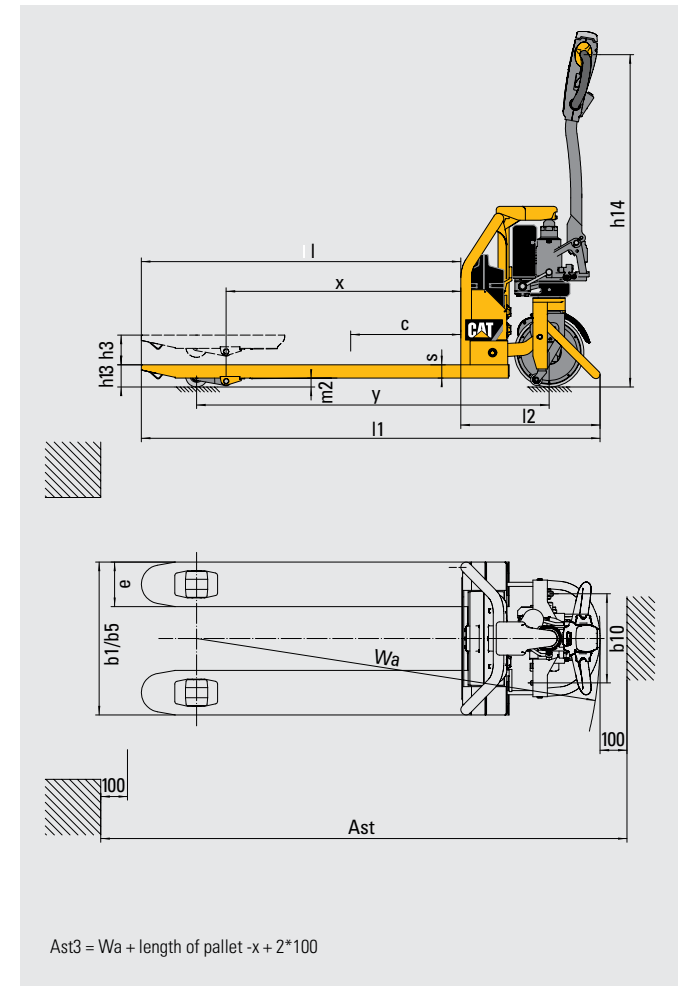

info@catliftruck.com | www.catliftruck.com

WESC1941(07/19) ©2019, MCFE. All Rights Reserved. CAT, CATERPILLAR, LET'S DO THE WORK, their respective logos, "Caterpillar Yellow", the "Power Edge" and Cat "Modern Hex" trade dress as well as corporate and product identity used herein, are trademarks of Caterpillar and may not be used without permission.

NOTE: Performance specifications may vary depending on standard manufacturing tolerances, vehicle condition, types of tyres, floor or surface conditions, applications, or operating environment. Trucks may be shown with non-standard options. Specific performance requirements and locally available configurations should be discussed with your Cat lift trucks Dealer. Cat Lift Trucks follows a policy of continual product improvement. For this reason, some materials, options and specifications could change without notice.



WATCH VIDEOS



DOWNLOAD OUR APP

